



# Agroflex®

## Marzo 2024

**CATÁLOGO  
DE PRODUCTOS**  
Nro 133 rev00





**Agroflex®**

# INDICE

Catálogo Marzo 2024 Nro 133 rev 00

|   |           |
|---|-----------|
| <b>BUSQUEDA POR CODIGO</b>                  | <b>3</b>  |
| <b>CUCHILLAS ROTO CUTTER <i>Nuevas!</i></b> | <b>4</b>  |
| <b>CUCHILLAS MIXER <i>Nuevas!</i></b>       | <b>5</b>  |
| <b>DESCOMPACTADORES</b>                     | <b>6</b>  |
| <b>REJAS CARPIDORAS <i>Nuevas!</i></b>      | <b>7</b>  |
| <b>LABRANZA</b>                             | <b>8</b>  |
| <b>FERTILIZACION / SIEMBRA</b>              | <b>10</b> |
| <b>APORCADORES PAPEROS</b>                  | <b>11</b> |
| <b>CUCHILLAS DESMALEZADORAS</b>             | <b>12</b> |
| <b>CUCHILLAS PARA MOVIMIENTO DE TIERRA</b>  | <b>22</b> |
| <b>CUCHILLAS PICADORAS</b>                  | <b>24</b> |
| <b>COSECHA</b>                              | <b>25</b> |

 Tel +54 9 341 576-8333 / +54 9 341 610-2987 / +54 341 457-0400

 [www.agroflex.com.ar](http://www.agroflex.com.ar)

 [agroflex@metaltecnica.com.ar](mailto:agroflex@metaltecnica.com.ar)

 [@agroflex.oficial](https://www.instagram.com/agroflex.oficial)

# BUSQUEDA POR CODIGO /

CATÁLOGO Nro 133 Marzo 2024

# Agroflex®

| CODIGO | PAG         |
|--------|-------------|
| 0017B  | 9           |
| 0018   | 9           |
| 0019   | 9           |
| 0022   | 9           |
| 0023   | 9           |
| 0026   | 8           |
| 0027   | 8           |
| 0031   | 8           |
| 0032   | 8           |
| 0033   | 8           |
| 034R   | 8           |
| 0036   | 8           |
| 0038   | 8           |
| 0041   | 9           |
| 0042   | 8           |
| 042R   | 8           |
| 0047   | 9           |
| 0049   | 9           |
| 0050S  | 9           |
| 0052   | 9           |
| 0053   | 9           |
| 0054   | 9           |
| 0056   | 9           |
| 0057   | 9           |
| 0065   | 9           |
| 0085   | 9           |
| 0089   | 9           |
| 0090   | 8           |
| 0110   | 9           |
| 0111   | 9           |
| 0115   | 9           |
| 0122   | 9           |
| 0128   | 8           |
| 0131   | 9           |
| 0141   | 9           |
| 0151   | 25          |
| 0154   | 9           |
| 0156   | 9           |
| 0179   | 9           |
| 0220   | 9           |
| 0243   | 25          |
| 0245   | 25          |
| 0246   | 25          |
| 0268   | 9           |
| 0293   | 9           |
| 0305   | 9           |
| 0316   | 9           |
| 0336   | 25          |
| 0375   | 25          |
| 0408   | 24          |
| 0434   | 14/15/17/18 |
| 0435   | 24          |
| 0437   | 24          |
| 0444   | 24          |
| 0449   | 22          |
| 0450   | 22          |
| 0451   | 22          |
| 0452   | 24          |
| 0453   | 12          |

| CODIGO                    | PAG      |
|---------------------------|----------|
| 0456                      | 23       |
| 0460                      | 23       |
| 0461                      | 23       |
| 0462                      | 23       |
| 0464                      | 22       |
| 0467                      | 22       |
| 0477                      | 16/17/18 |
| 0478                      | 23       |
| 0479                      | 23       |
| 0482                      | 22       |
| 0483                      | 22       |
| 0493                      | 12       |
| 0500-01                   | 20       |
| 0509                      | 21       |
| 0510                      | 14/21    |
| 0530                      | 13       |
| 0532                      | 13       |
| 0536                      | 13       |
| 0539                      | 13       |
| 0541-42                   | 20       |
| 0550                      | 13       |
| 0551                      | 13       |
| 0552                      | 13       |
| 0559                      | 16       |
| 0560                      | 16       |
| 0566                      | 16       |
| 0580                      | 24       |
| 0586                      | 22       |
| 0587                      | 22       |
| 0588                      | 22       |
| 0595                      | 18       |
| 0599                      | 18       |
| 0658                      | 23       |
| 0659                      | 23       |
| 0700C                     | 4        |
| 0707C                     | 4        |
| 0708C                     | 4        |
| 0709C                     | 4        |
| 0710C                     | 4        |
| 0710.1.C                  | 4        |
| 0710.2.C                  | 4        |
| 0710.3.C (pedir 0710.4.C) |          |
| 0710.4.C                  | 4        |
| 0710.5.C                  | 4        |
| 0710.6.C                  | 4        |
| 0710.7.C                  | 4        |
| 0711C                     | 4        |
| 0837                      | 12       |
| 0838                      | 19/20    |
| 0839                      | 14/19/21 |
| 0862                      | 15       |
| 0863                      | 15       |
| 0866                      | 14/19/21 |
| 0868                      | 19/20    |
| 0879                      | 22       |
| 0881                      | 21       |
| 0882                      | 23       |
| 0883                      | 23       |

| CODIGO   | PAG         |
|----------|-------------|
| 0900-1   | 5           |
| 0908-3   | 5           |
| 0908-4   | 5           |
| 0908-5   | 5           |
| 0908-5C  | 5           |
| 0908-5L  | 5           |
| 0908-7   | 5           |
| 0908-7-1 | 5           |
| 0908-8   | 5           |
| 0908-9   | 5           |
| 0909.C   | 5           |
| 0912     | 12          |
| 0914     | 25          |
| 0921     | 21          |
| 0922     | 13/15       |
| 0923     | 19          |
| 0940     | 21          |
| 0941     | 21          |
| 0949     | 6           |
| 0967     | 15          |
| 0980     | 24          |
| 0982     | 9           |
| 0983     | 9           |
| 0988     | 25          |
| 0989     | 12          |
| 0991     | 25          |
| 1051     | 13          |
| 1052     | 13          |
| 1053     | 13          |
| 1054     | 13          |
| 1082     | 9           |
| 1083     | 9           |
| 1124     | 14/19/21    |
| 1125     | 24          |
| 1129     | 20          |
| 1130     | 25          |
| 1147     | 14          |
| 1148     | 24          |
| 1156     | 9           |
| 1182     | 24          |
| 1183     | 24          |
| 1190     | 15          |
| 1191     | 15          |
| 1304     | 15          |
| 1390     | 18          |
| 1391     | 18          |
| 1392     | 18          |
| 1393     | 18          |
| 1468     | 22          |
| 1469     | 22          |
| 1472     | 23          |
| 1518     | 19/20       |
| 1540-21  | 15/16/17/20 |
| 1550     | 15          |
| 1646     | 17/18       |
| 1683     | 25          |
| 1691     | 9           |
| 1748     | 9           |
| 1766     | 15          |
| 1767     | 15          |

| CODIGO                 | PAG         |
|------------------------|-------------|
| 1773                   | 24          |
| 1938                   | 17          |
| 2030                   | 6           |
| 2042                   | 18          |
| 2046                   | 17          |
| 2047                   | 14          |
| 2048                   | 14/18       |
| 2051                   | 16/17/18/19 |
| 2052                   | 16/18       |
| 2076                   | 6           |
| 2080                   | 10          |
| 2099                   | 10          |
| 2136W                  | 6           |
| 2178                   | 10          |
| 2179                   | 10          |
| 2180                   | 10          |
| 2181                   | 10          |
| 2217                   | 15          |
| 2227                   | 15          |
| 2230                   | 24          |
| 2231                   | 24          |
| 2240                   | 15          |
| 2241                   | 19          |
| 2253                   | 5           |
| 2297                   | 11          |
| 2298                   | 11          |
| 2299                   | 11          |
| 2300                   | 11          |
| 2301                   | 11          |
| 2302                   | 11          |
| 2305                   | 11          |
| 2306                   | 11          |
| 2310                   | 11          |
| 2311                   | 11          |
| 2312                   | 11          |
| 2314                   | 11          |
| 2326                   | 5           |
| 2331                   | 18          |
| 2365 (0423)            | 6           |
| 2370 (0932)            | 6           |
| 2446                   | 18          |
| 2595                   | 18          |
| 2675 (0486/87)         | 14          |
| 2710                   | 11          |
| 2832                   | 19          |
| 2838 (1092-1 / 2838-1) | 6           |
| 2839-8 (2839)          | 6           |
| 2840-8 (2840)          | 6           |
| 2845 (2450)            | 6           |
| 2850                   | 6           |
| 2857                   | 15          |
| 2975                   | 7           |
| 2980                   | 7           |
| 2985                   | 7           |
| AG005985               | 4           |

# CUCHILLAS ROTO CUTTER /

CATÁLOGO Nro 133 Marzo 2024

## Nuevas!

# Agroflex®

**KRONE 0710.4.C**



**KRONE FORTIMA 0710.5.C**

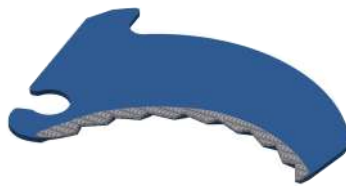

**KRONE MEGA (ENF) 0710.4.C**

ref. 0710.3.C



**YOMEL (ROTO) 0710C**



**YOMEL (ARROLLADORA) 0710.2.C**



**YOMEL MAGNA 940 0710.1.C**



**MC HALE - CKN00014**



**0710.6.C**  
ACORAZADA



**AG005985**  
SIN ACORAZAR

**CHALLENGER 0709C**



**NEW HOLLAND (ROTO) 0700C**



**NEW HOLLAND (ROTO) 0708C**



**LAS CUCHILLAS  
SON FABRICADAS EN  
ACERO BORO  
TEMPLADAS  
Y ACORAZADAS.-**

**MAINERO 44094-139 (MASCHIO) 0711C**

Antes código:  
44094139



**HESTON 0707C**

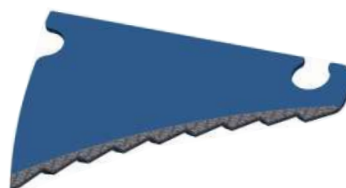

**MASSEY FERGUSON RB4180V 0710.7.C**

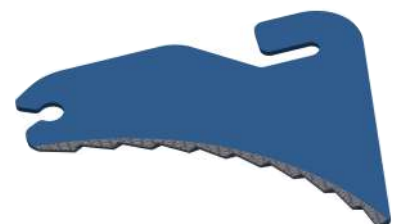

# CUCHILLAS MIXERS /

CATÁLOGO Nro 133 Marzo 2024

## Nuevas !

# Agroflex®

**AKRON 14322 0900-1**



**ASCANELLI CORTA 0908-5C**

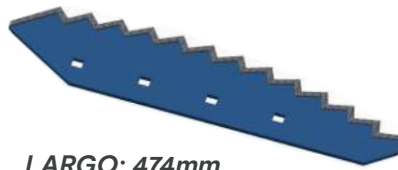

LARGO: 474mm  
13 DIENTES

**ASCANELLI LARGA 0908-5L**

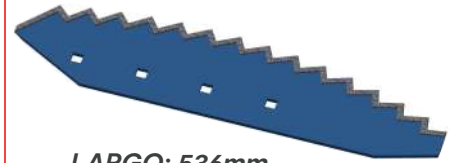

LARGO: 536mm  
15 DIENTES

**MAINERO 0908-9**

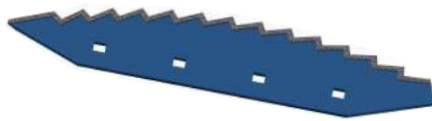

**GEA 0908-7**

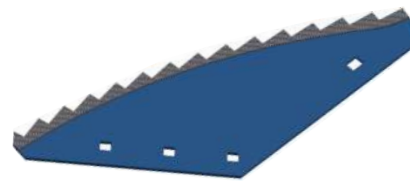

**GEA MOD. NUEVO 0908-7-1**

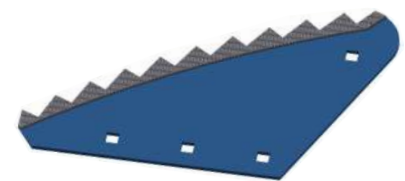

**JAYLOR PLANA 0908-5**

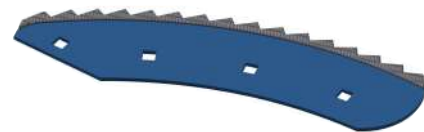

**JAYLOR PLEGADA 0908-8**



**LAS CUCHILLAS  
SON FABRICADAS EN  
ACERO BORO  
TEMPLADAS  
Y ACORAZADAS.-**

**MICELLI CORTA 0908-3**



**MICELLI LARGA 0908-4**



**TAURUS CHICA - APACHE 2326**



**MONTECOR - AGROMEC - JUAREZ- COMOFRA 0909.C**

LARGO: 450mm  
12 DIENTES



**MONTECOR - AGROMEC 2253**

LARGO: 503mm  
13 DIENTES





## SUBSOLADOR

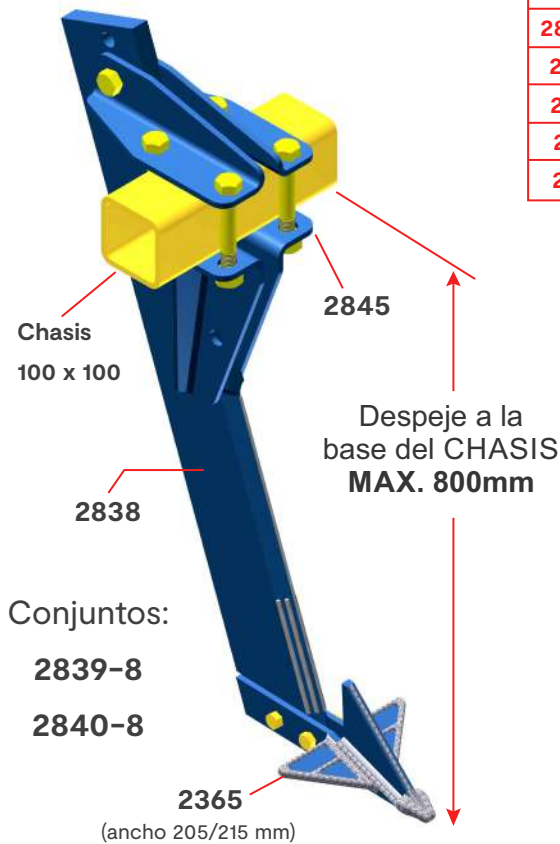

| CODIGO | DESCRIPCION                                 |
|--------|---|
| 2839-8 | CONJ. BRAZO SUBSOLADOR (PUA C/ALETAS SOLD.) |
| 2840-8 | CONJ. BRAZO SUBSOLADOR (PUA S/ALETAS SOLD.) |
| 2838   | BRAZO SUBSOLADOR Esp. 25mm C/FILO ACORAZADO |
| 2365   | PUA CON ALETAS SOLDADA (ancho 205/215 mm)   |
| 2370   | PUA SIN ALETAS SOLDADA (ancho 82/88 mm)     |
| 2845   | CONJ. SOP. (esp 8 mm) C/BULONES Y TUERCAS   |

EL SUBSOLADOR **Agroflex®** ELIMINA LA COMPACTACIÓN DE LAS CAPAS PROFUNDAS SU USO AUMENTA LA INFILTRACIÓN DE AGUA DISMINUYE LA POSIBILIDAD DE EROSIÓN Y FACILITA EL DESARROLLO DE LAS RAÍCES.

**POTENCIA REQUERIDA: 30 HP**  
**PROFUNDIDAD MAX.: 45 cm.**



Inserto 0949



P/brazo 1092-1  
modelo anterior

## ESCARIFICADOR

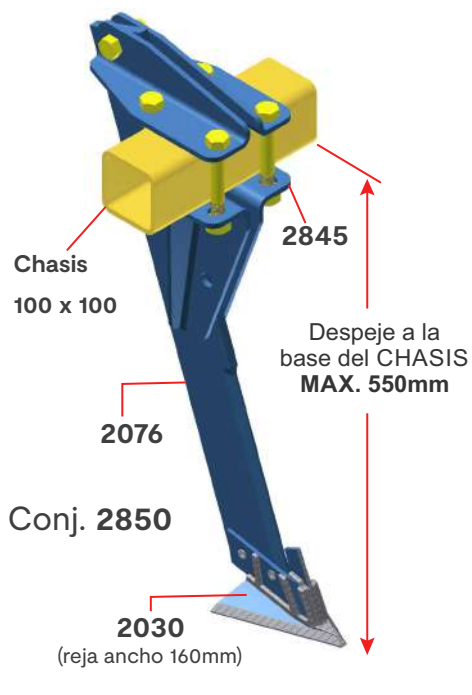

| CODIGO | DESCRIPCION                                  |
|--------|--|
| 2850   | CONJ. BRAZO ESCARIFICADOR                    |
| 2030   | REJA PARA BRAZO ESCARIFICADOR (Ancho 160 mm) |
| 2076   | BRAZO ESCARIFICADOR                          |
| 2845   | CONJ. SOP. (Esp 8 mm) C/BULONES Y TUERCAS    |

EL ESCARIFICADOR **Agroflex®** ELIMINA LA COMPACTACIÓN DE LAS CAPAS SUB-SUPERFICIALES SU USO AUMENTA LA INFILTRACIÓN DE AGUA DISMINUYE LA POSIBILIDAD DE EROSIÓN Y FACILITA EL DESARROLLO DE LAS RAÍCES.

**POTENCIA REQUERIDA: 15 HP**  
**PROFUNDIDAD MAX.: 25 cm.**

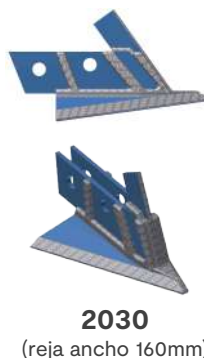

# REJAS CARPIDORAS /

CATÁLOGO Nro 133 Marzo 2024

**Nuevas!**

**Agroflex®**

| CODIGO | DESCRIPCION                                |
|--------|--|
| 2975   | REJA CARPIDORA ANCHO 540mm ACORAZADA       |
| 2980   | REJA CARPIDORA ANCHO 780mm ACORAZADA       |
| 2985   | SOPORTE P/REJA CARPIDORA EN ARCO DE CINCEL |

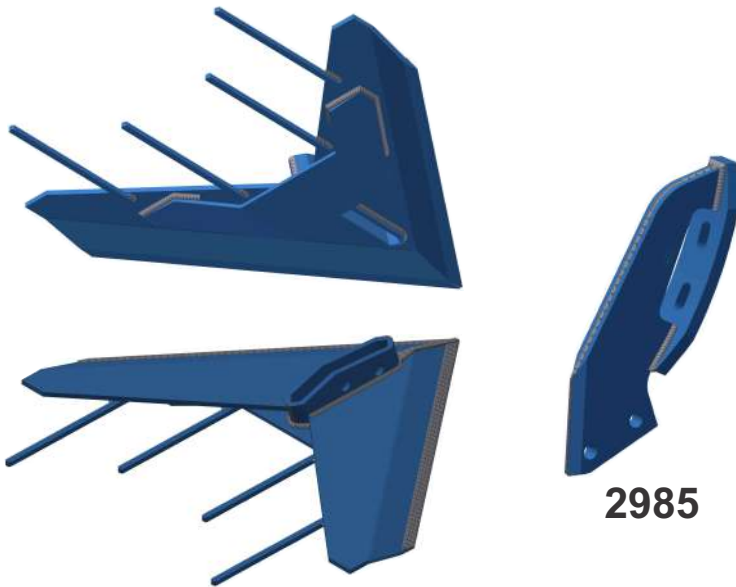

2975

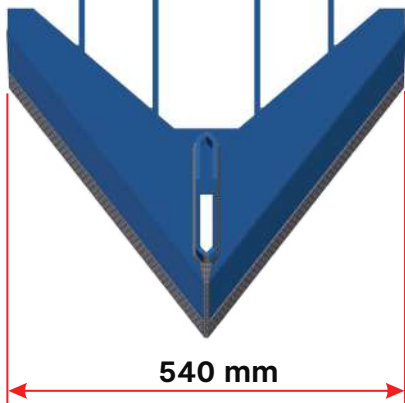

540 mm

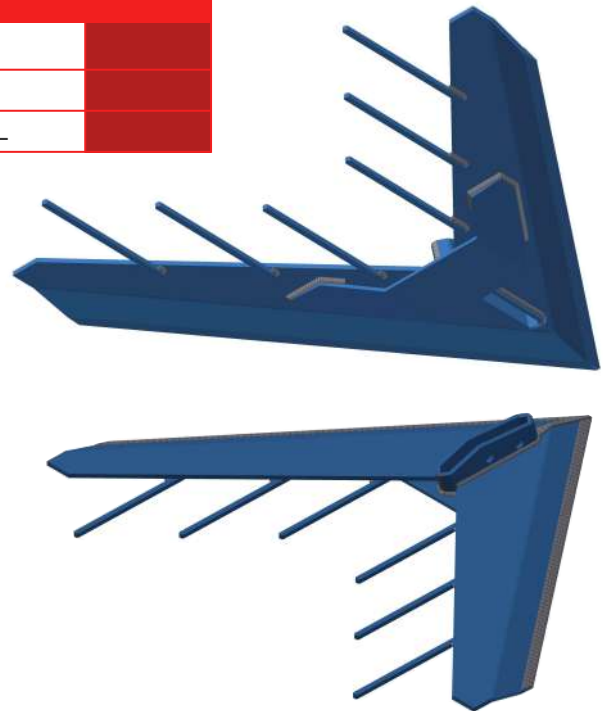

2980

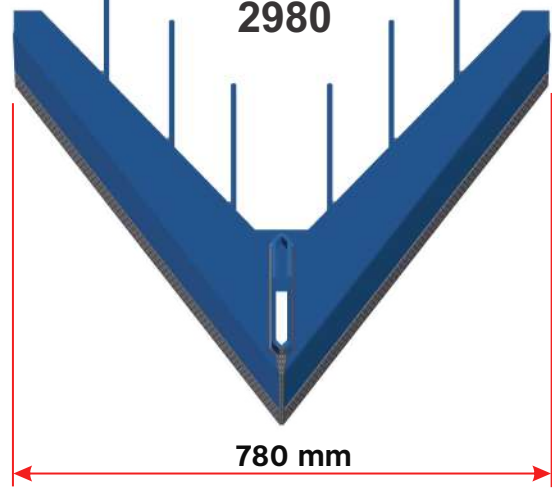

780 mm

## MONTAJE EN ARCO DE CINCEL

- 0953 x2 bulón W 1/2" 2 1/2"
- 0065 opc. bulón cab. cónica
- 0007 x2 arandela plana 1/2"
- 0013 x2 tuerca 1/2"

2024  
esp. elast. x2  
D14.6x35mm



2975  
2980

2985

## MONTAJE EN BRAZO ESCARIFICADOR SUBSOLADOR

2024  
esp. elast. x2  
D14.6x35mm

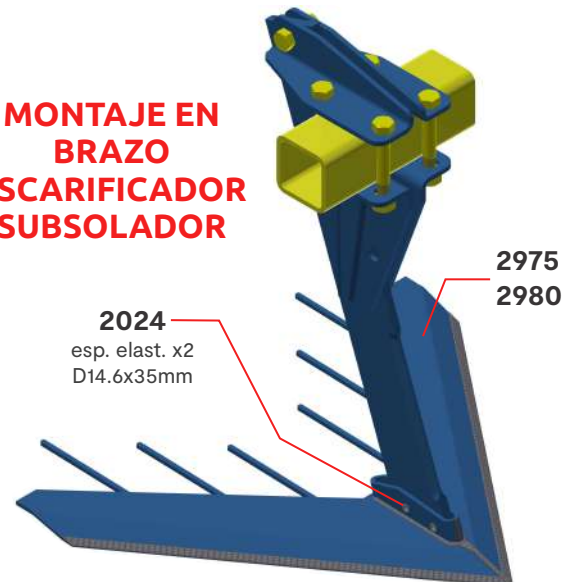

2975  
2980

| ARCOS 2" X 1"  |  |  |
|--|--|--|
| <b>0026</b>  | <b>0027</b>  | <b>0031</b>  |
| CHIAPANO - CELEBA  | INTERNACIONAL - STIMA - SUPER BONG<br>AGROMETAL - BUDASSI - EL CHALERO | FUN CAS - MIGRA - AGRO RAS   |
|  |  |  |
| <b>0032</b>  | <b>0033</b>  | <b>0036</b>  |
| DISTRIMAQ - CRUCIANELLI  | GHERARDI - Fabr. UNIDAS  | JOHN DEERE - ACHILLI Y DIBATISTA - CELE<br>SUPER DAN - NIEVAS - ERCA - GIAROLI<br>AGROMEC - DAN CAR - MET. ARMSTRONG |
|  |  |  |
| <b>0042</b>  | <b>0090</b>  | <b>0128</b>  |
| CORTI - AGROMETAL - INDASO - DU MAIRE<br>COENDA - VIALCALM - PEHUENCHE | TEMPLAR - MET. ARGENTINA - JUBER<br>NOBILE - IMPAGRO - MORO            | GIORGI - GIAROLI - PROMI - WALTER<br>AGROMETAL - CHALERO - BORGATTI<br>ROBUSTO - YOMEL                               |
|  |  |  |

| ARCOS 2" X 1 1/4" |   |  |
|-------------------|---|--|
| <b>034R</b>       | <b>042R</b>   |  |
| GIORGI            | CORTI - AGROMETAL - INDASO<br>COENDA - VIALCALM - PEHUENCHE |  |
|                   |   |  |



## CINCEL

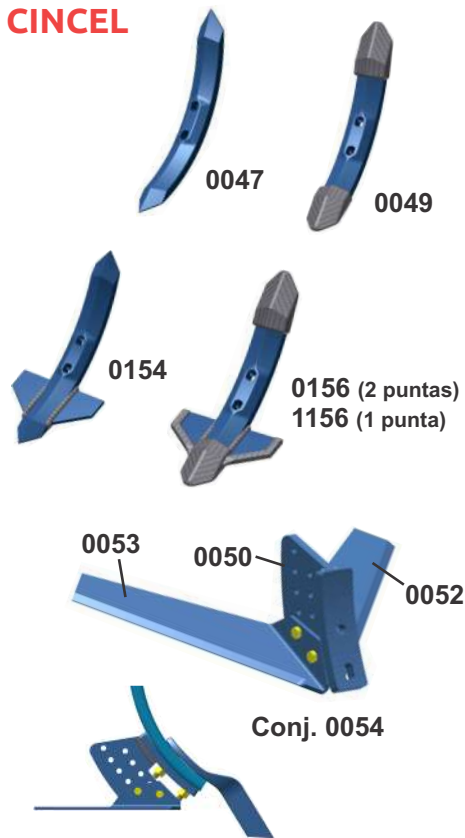

| CODIGO | DESCRIPCION                                       |
|--------|---|
| 0047   | PUA CINCEL FORJADA sin acorazar                   |
| 0049   | PUA CINCEL FORJADA ACORAZADA                      |
| 0056   | PUA DE PRADERA P/CINCEL sin acorazar              |
| 0154   | PUA TURBO CINCEL sin acorazar                     |
| 0156   | PUA TURBO CINCEL ACORAZADA 2 PUNTAS               |
| 1156   | PUA TURBO CINCEL ACORAZADA 1 PUNTA                |
| 0057   | REJA PIE DE PATO PARA CINCEL 7"                   |
| 0220   | REJA PIE DE PATO PARA CINCEL 7" ACORAZADA         |
| 0982   | REJA CINCEL CULTIVADOR 14"                        |
| 0983   | REJA CINCEL CULTIVADOR 14" ACORAZADA              |
| 1082   | REJA PLANA CINCEL CULTIVADOR 18"                  |
| 1083   | REJA PLANA CINCEL CULTIVADOR 18" ACORAZADA        |
| 0050S  | SOPORTE ALETAS DESMALEZADORAS                     |
| 0052   | ALETA DESMALEZADORA IZQUIERDA                     |
| 0053   | ALETA DESMALEZADORA DERECHA                       |
| 0054   | CONJ. ALETAS DESMALEZADORAS / BULONES             |
| 0141   | CONJ. SOPORTE ARCO FIJO PARA CINCEL               |
| 0065   | BULON PARA PUA DE CINCEL C/TUERCA 1/2" x 2 1/2"   |
| 0089   | BULON PARA PUA DE CINCEL C/TUERCA 1/2" x 3"       |
| 0115   | BULON CABEZA FRESADA PARA REJA C/TUERCA 1/2" x 2" |
| 0179   | GRAMPA DE ACERO C/TUERCA 4" x 4" x 3/4"           |



## VIBROCULTIVADOR

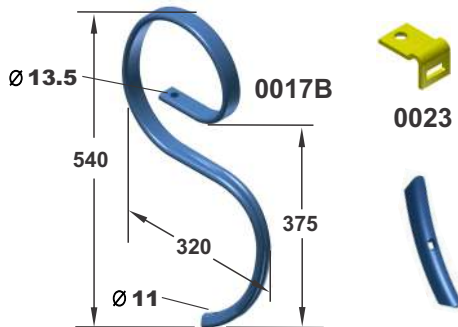

| CODIGO | DESCRIPCION   |
|--------|---|
| 0017B  | ARCO VIBRO BAJO                                     |
| 0018   | PUA REVERSIBLE                                      |
| 0038   | REJA PIE PATO 4"                                    |
| 0316   | REJA PIE PATO 7"                                    |
| 0023   | SOPORTE P/ARCO VIBRO "S" P/PLANCH. 51x13            |
| 0019   | BULON DE ACERO C/TUERCA PARA REJA 3/8" x 1 1/2"     |
| 0022   | BULON DE ACERO C/TUERCA EXCENTRICO DE 1/2" x 1 3/4" |

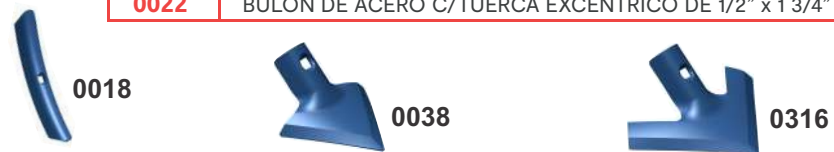

## CULTIVADOR DE CAMPO

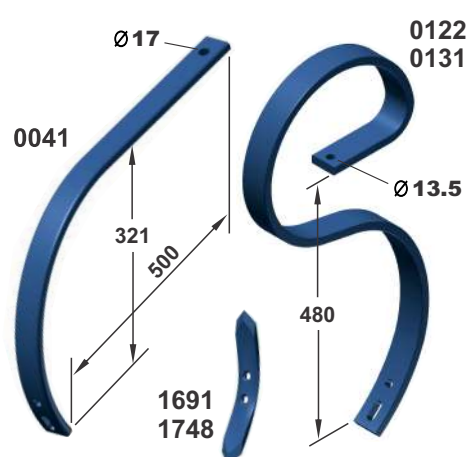

| CODIGO | DESCRIPCION                                      |
|--------|--|
| 0041   | ARCO FLEXIBLE TIPO "C"                           |
| 0122   | BRAZO FLEX. TIPO "S" (FORJADO Mod. NIEVAS)       |
| 0131   | BRAZO FLEX. TIPO "S" ASIENTO PLANO 44.4x14.3     |
| 1691   | PUA REVERSIBLE P/CULTIV. DE CAMPO                |
| 1748   | PUA REVERSIBLE P/CULTIV. DE CAMPO ACORAZADA      |
| 0085   | REJA PIE DE PATO 11" (ASIENTO PLANO)             |
| 0293   | REJA PIE DE PATO 11" ACORAZADA (ASIENTO PLANO)   |
| 0111   | REJA PIE DE PATO 11" (ASIENTO CURVO)             |
| 0305   | REJA CULTIV. CAMPO 11" ACORAZADA (asiento curvo) |
| 0268   | SUJETADOR BRAZO "S" (TUBO 70x70)                 |
| 0110   | BULON DE ACERO CEMENTADO DE 7/16" x 1 3/4"       |



# FERTILIZACION / SIEMBRA

CATÁLOGO Nro 133 Marzo 2024

# Agroflex®

**2080**

PUA FERTILIZADORA CON GUIA TUBO

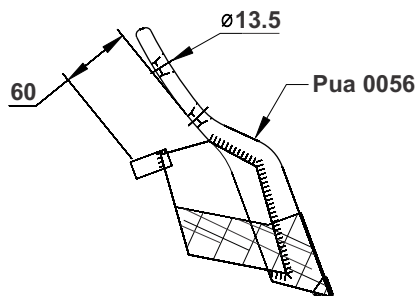

**2630**  
CONJ. ZAPATA  
FERTILIZADORA

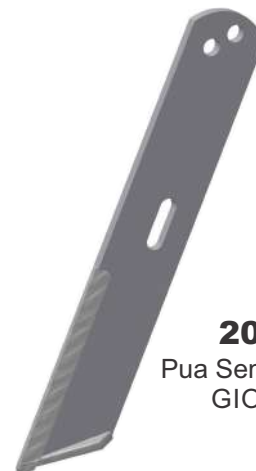

**2099**  
Pua Sembradora  
GIORGI

**2179**

CONJ. ZAPATA FERTILIZADORA

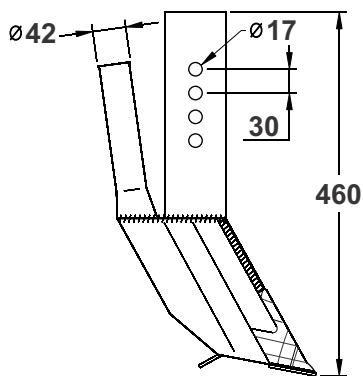

**2180**

CONJ. ZAPATA FERTILIZADORA

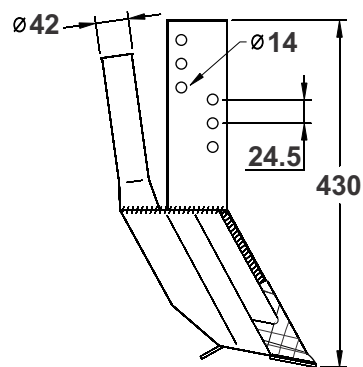

**2181**

CONJ. ZAPATA FERTILIZADORA

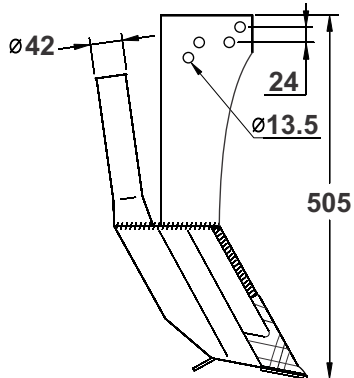

**2178**

RECAMBIO ZAPATA FERT. SOLIDO

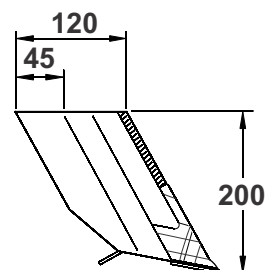

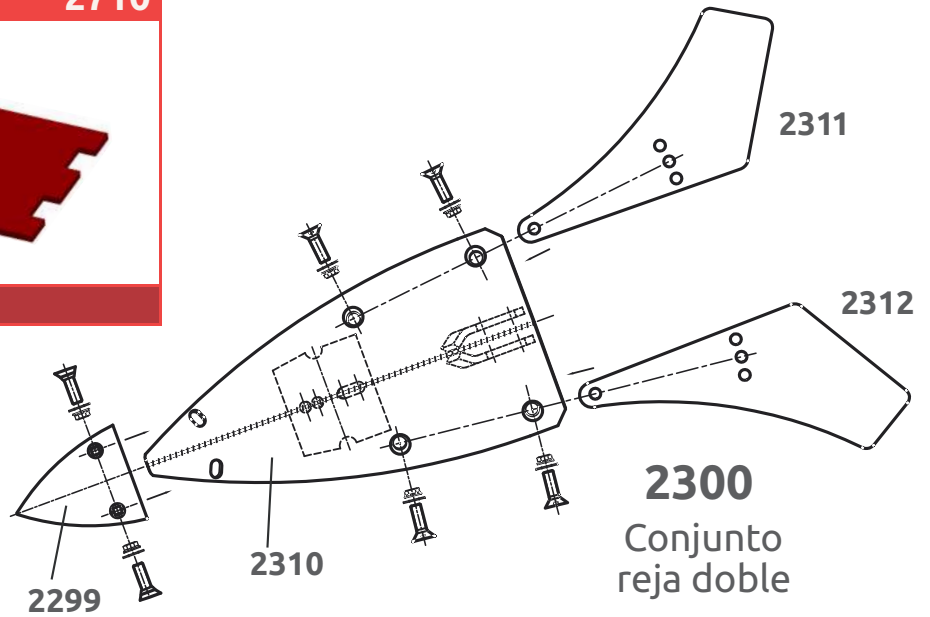

| CODIGO      | DESCRIPCION                              |
|-------------|--|
| <b>2300</b> | CONJ. REJA DOBLE APORCADORA              |
| <b>2301</b> | CONJ. REJA IZQUIERDA APORCADORA          |
| <b>2302</b> | CONJ. REJA DERECHA APORCADORA            |
| <b>2314</b> | BRAZO 63,5 x 25,4mm (ARCO) SOPORTE REJAS |
| <b>2311</b> | PROLONGACIÓN REJA IZQUIERDA              |
| <b>2312</b> | PROLONGACIÓN REJA DERECHA                |
| <b>2299</b> | PUNTA REJA DOBLE                         |
| <b>2305</b> | MEDIA PUNTA REJA IZQUIERDA               |
| <b>2306</b> | MEDIA PUNTA REJA DERECHA                 |
| <b>2297</b> | CONJ. SOLDADO REJA IZQUIERDA             |
| <b>2298</b> | CONJ. SOLDADO REJA DERECHA               |
| <b>2310</b> | CONJ. SOLDADO REJA DOBLE                 |

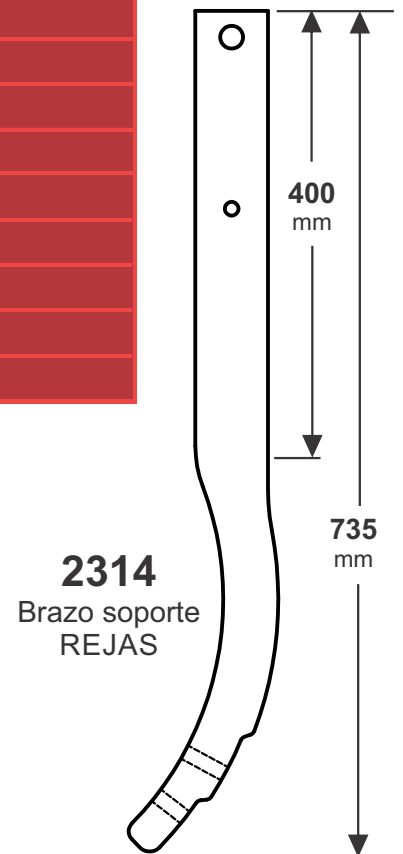
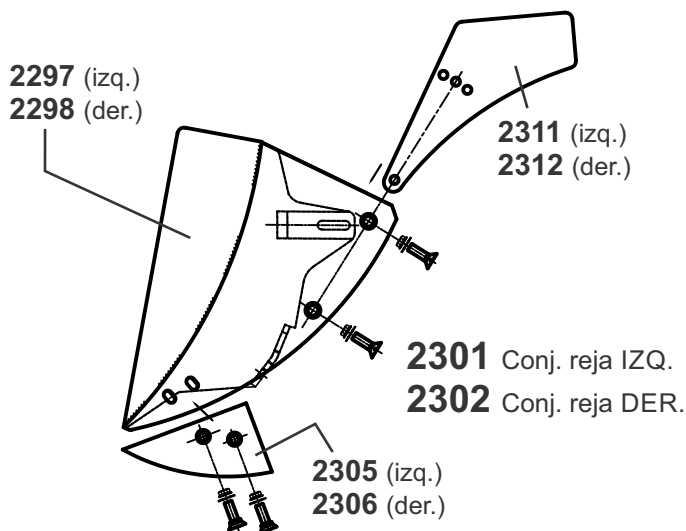

# CUCHILLAS DESMALEZADORAS /

CATÁLOGO Nro 133 Marzo 2024

| AGRO-AR - TC 1500 |      |  |       |      |  |       |      |  |
|-------------------|------|--|-------|------|--|-------|------|--|
| OSCILANTES        |      |  | FIJAS |      |  | BUJE  |      |  |
| CANT.             | COD. |  | CANT. | COD. |  | CANT. | COD. |  |
| 2                 | 0493 |  | 2     | 0912 |  | 2     | 0453 |  |
|                   |      |  |       |      |  |       |      |  |

| AGRO-AR - TC 2500 |      |  |       |      |  |       |      |  |
|-------------------|------|--|-------|------|--|-------|------|--|
| OSCILANTES        |      |  | FIJAS |      |  | BUJE  |      |  |
| CANT.             | COD. |  | CANT. | COD. |  | CANT. | COD. |  |
| 4                 | 0493 |  | 4     | 0912 |  | 4     | 0453 |  |
|                   |      |  |       |      |  |       |      |  |

| AGRO-AR - HD 3092 |      |  |       |      |  |       |      |  |
|-------------------|------|--|-------|------|--|-------|------|--|
| OSCILANTES        |      |  | FIJAS |      |  | BUJE  |      |  |
| CANT.             | COD. |  | CANT. | COD. |  | CANT. | COD. |  |
| 4                 | 0493 |  | 4     | 0989 |  | 4     | 0453 |  |
|                   |      |  |       |      |  |       |      |  |

| AGRO-AR - DA 4392 |      |  |       |      |  |                |      |  |
|-------------------|------|--|-------|------|--|----------------|------|--|
| OSCILANTES        |      |  | FIJAS |      |  | PORTACUCHILLAS |      |  |
| CANT.             | COD. |  | CANT. | COD. |  | CANT.          | COD. |  |
| 6                 | 0837 |  | 6     | 0989 |  | 6              | 0453 |  |
|                   |      |  |       |      |  |                |      |  |

# CUCHILLAS DESMALEZADORAS /

CATÁLOGO Nro 133 Marzo 2024

| AGROMEC-DA 302 |      |  | AGROMEC-DH 300 |      |  | AGROMEC-DH 300 |      |  | AGROMEC-DH 300 |      |  |
|----------------|------|--|----------------|------|--|----------------|------|--|----------------|------|--|
| OSCILANTES     |      |  | OSCILANTES     |      |  | OSCILANTES     |      |  | FIJAS          |      |  |
| CANT.          | COD. |  | CANT.          | COD. |  | CANT.          | COD. |  | CANT.          | COD. |  |
| 4              | 0922 |  | 2 (AH)         | 1051 |  | 2 (AH)         | 1052 |  | 2 (H)          | 1053 |  |
|                |      |  |                |      |  |                |      |  |                |      |  |

| ANCA-HD 300                               |      |  | ANCA-HD 300 |      |  | ANCA-HD 300 |      |  |
|---|------|--|-------------|------|--|-------------|------|--|
| OSCILANTES                                |      |  | FIJAS       |      |  | PERNO       |      |  |
| CANT.                                     | COD. |  | CANT.       | COD. |  | CANT.       | COD. |  |
| 4   | 0550 |  | 4           | 0551 |  | 4           | 0552 |  |
| <p>DOBLE FILO REEMPLAZA A 0548 Y 0549</p> |      |  |             |      |  |             |      |  |

| ARDANAZ - BD - BF (1,50 m) |      |  | ARDANAZ - BD - BF (1,50 m) |      |  | ARDANAZ - BD - BF (1,50 m) |      |  |
|----------------------------|------|--|----------------------------|------|--|----------------------------|------|--|
| OSCILANTES                 |      |  | PERNO                      |      |  | ARDANAZ - BD - BF (1,50 m) |      |  |
| CANT.                      | COD. |  | CANT.                      | COD. |  | CANT.                      | COD. |  |
| 2                          | 0530 |  | 2                          | 0536 |  |                            |      |  |
|                            |      |  |                            |      |  |                            |      |  |

| ARDANAZ - D1 (2,68 y 3,00 m) |      |  | ARDANAZ - DH260 - DH300 |      |  | ARDANAZ - DH260 - DH300 |      |  |
|------------------------------|------|--|-------------------------|------|--|-------------------------|------|--|
| OSCILANTES                   |      |  | PERNO                   |      |  | OSCILANTES              |      |  |
| CANT.                        | COD. |  | CANT.                   | COD. |  | CANT.                   | COD. |  |
| 4                            | 0530 |  | 4                       | 0539 |  | 4                       | 0532 |  |
|                              |      |  |                         |      |  |                         |      |  |

(AH) AntiHorario / (H) Horario: SENTIDO DE GIRO



# CUCHILLAS DESMALEZADORAS /

CATÁLOGO Nro 133 Marzo 2024

| BAIMA - B285 - B385 - B400 |      |  |   |
|----------------------------|------|--|---|
| OSCILANTES                 |      |  | NOTA:   |
| CANT.                      | COD. |  |   |
| 4                          | 2048 |  |   |
|                            |      |  | <p>La cuchilla oscilante <b>2048</b> es doble filo y <b>reemplaza</b> a las anteriores <b>0494</b> y <b>0495</b>.<br/>Se puede utilizar también para los Mod. <b>B385</b> y <b>B400</b></p> |

| BAIMA - B4300 (3 cuerpos) |      |  |       |      |                         |  |                  |  |  |
|---------------------------|------|--|-------|------|-------------------------|--|------------------|--|--|
| OSCILANTES                |      |  | FIJAS |      | Conj. PERNO             |  | BUJE             |  |  |
| CANT.                     | COD. |  | CANT. | COD. | COD.                    |  | COD.             |  |  |
| 6                         | 1124 |  | 6     | 0510 | Conj. Perno <b>0839</b> |  | Buje <b>0866</b> |  |  |
|                           |      |  |       |      |                         |  |                  |  |  |

| CERUTTI - CMC 150 |      |  |       |      |  |  |
|-------------------|------|--|-------|------|--|--|
| OSCILANTES        |      |  | PERNO |      |  | NOTA:  |
| CANT.             | COD. |  | CANT. | COD. |  |  |
| 2                 | 2047 |  | 2     | 1147 |  |  |
|                   |      |  |       |      |  | <p>Las cuchillas oscilantes <b>2047</b> son doble filo y reemplazan a las anteriores <b>0582</b></p> |

| CERUTTI - CMC 300 |      |  |                                      |      |       |      |  |  |  |
|-------------------|------|--|--------------------------------------|------|-------|------|--|--|--|
| OSCILANTES        |      |  | FIJAS                                |      | PERNO |      | NOTA:  |  |  |
| CANT.             | COD. |  | CANT.                                | COD. | CANT. | COD. |  |  |  |
| 4                 | 2047 |  | 4                                    | 2675 | 4     | 1147 |  |  |  |
|                   |      |  | <p>(antes: 0486 AHx2 / 0487 Hx2)</p> |      |       |      | <p>Las cuchillas oscilantes <b>2047</b> son doble filo y reemplazan a las anteriores <b>0582</b></p> |  |  |

(AH) AntiHorario / (H) Horario: SENTIDO DE GIRO

# CUCHILLAS DESMALEZADORAS /

CATÁLOGO Nro 133 Marzo 2024

| CERUTTI - DH 300 |      |  |       |      |  |       |      |  |  |
|------------------|------|--|-------|------|--|-------|------|--|--|
| OSCILANTES       |      |  | FIJAS |      |  | PERNO |      |  |  |
| CANT.            | COD. |  | CANT. | COD. |  | CANT. | COD. |  |  |
| 4                | 0922 |  | 4     | 1304 |  | 4     | 0967 |  |  |
|                  |      |  |       |      |  |       |      |  |  |

| DEUTZ TATU 4200 - 4500 |      |  |
|------------------------|------|--|
| OSCILANTES             |      |  |
| CANT.                  | COD. |  |
| 2 (AH)                 | 0862 |  |
| 4 (H)                  | 0863 |  |
|                        |      |  |

| DHG 3200   |      |  |
|------------|------|--|
| OSCILANTES |      |  |
| CANT.      | COD. |  |
| 4          | 2240 |  |
|            |      |  |

| EL NORTEÑO |         |  |
|------------|---------|--|
| OSCILANTES |         |  |
| CANT.      | COD.    |  |
| 4          | 1540-21 |  |
|            |         |  |

| FAMAQ      |         |  |
|------------|---------|--|
| OSCILANTES |         |  |
| CANT.      | COD.    |  |
| 4          | 1540-21 |  |
|            |         |  |

| GIMETAL    |      |  |            |      |  |            |      |  |
|------------|------|--|------------|------|--|------------|------|--|
| OSCILANTES |      |  | OSCILANTES |      |  | OSCILANTES |      |  |
| CANT.      | COD. |  | CANT.      | COD. |  | CANT.      | COD. |  |
| s/modelo   | 2227 |  | s/modelo   | 1766 |  | s/modelo   | 1767 |  |
|            |      |  |            |      |  |            |      |  |

| GROSSPAL EG 300 y Mod. AV 200 |      |  |            |  | GROSSPAL VG 300 VIALCALM |      |  |        |      |       |       |      |  |       |      |  |  |  |  |
|-------------------------------|------|--|------------|--|--------------------------|------|--|--------|------|-------|-------|------|--|-------|------|--|--|--|--|
| OSCILANTES                    |      |  |            |  | OSCILANTES               |      |  |        |      | FIJAS |       |      |  |       |      |  |  |  |  |
| CANT.                         | COD. |  | COD.       |  | CANT.                    | COD. |  | CANT.  | COD. |       | CANT. | COD. |  | CANT. | COD. |  |  |  |  |
| s/modelo                      | 2217 |  | Buje: 2857 |  | 4                        | 1550 |  | 2 (AH) | 1190 |       | 2 (H) | 1191 |  |       |      |  |  |  |  |
|                               |      |  |            |  |                          |      |  |        |      |       |       |      |  |       |      |  |  |  |  |

(AH) AntiHorario / (H) Horario: SENTIDO DE GIRO

# CUCHILLAS DESMALEZADORAS /

CATÁLOGO Nro 133 Marzo 2024

| HILCOR - HL300 - 260 |         |       |      |
|----------------------|---------|-------|------|
| OSCILANTES           |         | FIJAS |      |
| CANT.                | COD.    | CANT. | COD. |
| 4                    | 1540-21 | 4     | 2051 |

Las cuchillas fijas 2051 son doble filo y reemplazan a las anteriores 0496 y 0497

| HILCOR - HA320 |         |       |      |
|----------------|---------|-------|------|
| OSCILANTES     |         | FIJAS |      |
| CANT.          | COD.    | CANT. | COD. |
| 4              | 1540-21 | 4     | 2052 |

Las cuchillas fijas 2052 son doble filo y reemplazan a las anteriores 0498 y 0499

| HILCOR - H2T |         |       |      |
|--------------|---------|-------|------|
| OSCILANTES   |         | FIJAS |      |
| CANT.        | COD.    | CANT. | COD. |
| 4            | 1540-21 | 4     | 2052 |

Las cuchillas fijas 2052 son doble filo y reemplazan a las anteriores 0498 y 0499

| HILCOR - H5400 |         |       |      |
|----------------|---------|-------|------|
| OSCILANTES     |         | FIJAS |      |
| CANT.          | COD.    | CANT. | COD. |
| 8              | 1540-21 | 8     | 2051 |

Las cuchillas fijas 2051 son doble filo y reemplazan a las anteriores 0496 y 0497

| HILCOR - H360 |      |       |      |
|---------------|------|-------|------|
| OSCILANTES    |      | FIJAS |      |
| CANT.         | COD. | CANT. | COD. |
| 2 (H)         | 0559 | 4     | 2051 |
| 2 (AH)        | 0560 |       |      |

Las cuchillas fijas 2051 son doble filo y reemplazan a las anteriores 0496 y 0497

| HILCOR - BMT170 |      |       |      |
|-----------------|------|-------|------|
| OSCILANTES      |      | FIJAS |      |
| CANT.           | COD. | CANT. | COD. |
| 2 (AH)          | 0560 | 2     | 2052 |

Las cuchillas fijas 2052 son doble filo y reemplazan a las anteriores 0498 y 0499

| HILCOR - BMT150V |      |       |      |
|------------------|------|-------|------|
| OSCILANTES       |      | PERNO |      |
| CANT.            | COD. | CANT. | COD. |
| 2 (AH)           | 0566 | 2     | 0477 |
|                  |      | 2     | 0434 |

(AH) AntiHorario / (H) Horario: SENTIDO DE GIRO

# CUCHILLAS DESMALEZADORAS /

CATÁLOGO Nro 133 Marzo 2024

| HILCOR - BMT 130 - 150 |         |  | HILCOR - HM220 - TP220 |      |  |
|------------------------|---------|--|------------------------|------|--|
| OSCILANTES             |         |  | OSCILANTES             |      |  |
| CANT.                  | COD.    |  | CANT.                  | COD. |  |
| 2                      | 1540-21 |  | 4                      | 2046 |  |
|                        |         |  |                        |      |  |

| HILCOR - HM221 |      |       |
|----------------|------|-------|
| OSCILANTES     |      | PERNO |
| CANT.          | COD. | CANT. |
| 4              | 1938 | 4     |
|                |      | 4     |
|                |      | 0477  |
|                |      | 0434  |
|                |      |       |

| HILCOR - HM261 |      |       |       |
|----------------|------|-------|-------|
| OSCILANTES     |      | FIJAS | PERNO |
| CANT.          | COD. | CANT. | COD.  |
| 4              | 1646 | 4     | 2051  |
|                |      | 4     | 0477  |
|                |      | 4     | 0434  |
|                |      |       |       |

| HILCOR - HM301 |      |       |       |
|----------------|------|-------|-------|
| OSCILANTES     |      | FIJAS | PERNO |
| CANT.          | COD. | CANT. | COD.  |
| 4              | 1646 | 4     | 2051  |
|                |      | 4     | 0477  |
|                |      | 4     | 0434  |
|                |      |       |       |

(AH) AntiHorario / (H) Horario: SENTIDO DE GIRO

# CUCHILLAS DESMALEZADORAS /

CATÁLOGO Nro 133 Marzo 2024

| HILCOR - HM361 |      |  |       |      |  |       |      |  |
|----------------|------|--|-------|------|--|-------|------|--|
| OSCILANTES     |      |  | FIJAS |      |  | PERNO |      |  |
| CANT.          | COD. |  | CANT. | COD. |  | CANT. | COD. |  |
| 4              | 1646 |  | 4     | 2052 |  | 4     | 0477 |  |
|                |      |  |       |      |  | 4     | 0434 |  |

| HUICI - CRH150 - CRT150 - CRL150 - CRL3100 |      |  |  |  |  |  |  |  |
|--|------|--|--|--|--|--|--|--|
| OSCILANTES                                 |      |  |  |  |  |  |  |  |
| CANT.                                      | COD. |  |  |  |  |  |  |  |
| 2  | 2042 |  |  |  |  |  |  |  |

La cuchilla oscilante **2042** es doble filo y **reemplaza** a las anteriores **0519** y **0522**

| MAINERO - 6026 - 6027 - 6042 |      |  |            |      |  |  |  |  |
|------------------------------|------|--|------------|------|--|--|--|--|
| OSCILANTES                   |      |  | OSCILANTES |      |  |  |  |  |
| CANT.                        | COD. |  | CANT.      | COD. |  |  |  |  |
| 8                            | 0595 |  | 8          | 2595 |  |  |  |  |

Las cuchillas 0595/2595 están fresadas del lado de abajo

| MARINOZZI  |      |  |  |  |  |  |  |  |
|------------|------|--|--|--|--|--|--|--|
| OSCILANTES |      |  |  |  |  |  |  |  |
| CANT.      | COD. |  |  |  |  |  |  |  |
| 4          | 0599 |  |  |  |  |  |  |  |

| METALBERT  |      |  |            |      |  |  |  |  |
|------------|------|--|------------|------|--|--|--|--|
| OSCILANTES |      |  | OSCILANTES |      |  |  |  |  |
| CANT.      | COD. |  | CANT.      | COD. |  |  |  |  |
| 4          | 2331 |  | 2          | 2446 |  |  |  |  |

Reemplaza 1061/1062

| MONTERREY - DM 2900 E |      |  |        |      |  |  |  |  |
|-----------------------|------|--|--------|------|--|--|--|--|
| OSCILANTES            |      |  | FIJAS  |      |  |  |  |  |
| CANT.                 | COD. |  | CANT.  | COD. |  |  |  |  |
| 4                     | 2048 |  | 2 (AH) | 1392 |  |  |  |  |
|                       |      |  | 2 (H)  | 1393 |  |  |  |  |

Alter. p/1390-1391

(AH) AntiHorario / (H) Horario: SENTIDO DE GIRO



# CUCHILLAS DESMALEZADORAS /

CATÁLOGO Nro 133 Marzo 2024

| OMBU       |      |  |                      |      |  |
|------------|------|--|----------------------|------|--|
| OSCILANTES |      |  | OSCILANTES           |      |  |
| CANT.      | COD. |  | CANT.                | COD. |  |
| 4          | 2241 |  | 4                    | 2832 |  |
|            |      |  | <p><b>Nueva!</b></p> |      |  |

| RJS - DA 3000 - DA 4500 - DA 5400 |      |  |       |      |  |                         |      |  |                  |      |  |
|-----------------------------------|------|--|-------|------|--|-------------------------|------|--|------------------|------|--|
| OSCILANTES                        |      |  | FIJAS |      |  | Conj. PERNO             |      |  | BUJE             |      |  |
| CANT.                             | COD. |  | CANT. | COD. |  | CANT.                   | COD. |  | CANT.            | COD. |  |
| 4 (AH)                            | 1124 |  | 4     | 2051 |  | Conj. Perno <b>0839</b> |      |  | Buje <b>0866</b> |      |  |
|                                   |      |  |       |      |  |                         |      |  |                  |      |  |

| RJS - D 1200 - D 1500 - D 1800 - DLA 1500 - DH 3400 |      |  |       |      |  |                         |      |  |                  |      |  |
|---|------|--|-------|------|--|-------------------------|------|--|------------------|------|--|
| OSCILANTES  |      |  | FIJAS |      |  | Conj. PERNO             |      |  | BUJE             |      |  |
| CANT.   | COD. |  | CANT. | COD. |  | CANT.                   | COD. |  | CANT.            | COD. |  |
| 2   | 1518 |  | 2     | 2051 |  | Conj. Perno <b>0838</b> |      |  | Buje <b>0868</b> |      |  |
|   |      |  |       |      |  |                         |      |  |                  |      |  |

| RJS - DH 3000 - DHA 4500 |      |  |       |      |  |       |      |  |       |      |  |
|--------------------------|------|--|-------|------|--|-------|------|--|-------|------|--|
| OSCILANTES               |      |  | FIJAS |      |  |       |      |  |       |      |  |
| CANT.                    | COD. |  | CANT. | COD. |  | CANT. | COD. |  | CANT. | COD. |  |
| 8                        | 0923 |  | 8     | 2051 |  |       |      |  |       |      |  |
|                          |      |  |       |      |  |       |      |  |       |      |  |

(AH) AntiHorario / (H) Horario: SENTIDO DE GIRO

# CUCHILLAS DESMALEZADORAS /

CATÁLOGO Nro 133 Marzo 2024

| SPINA - SS |         |  | SPINA - SP1600 - SP 3 1600 |         |  |
|------------|---------|--|----------------------------|---------|--|
| OSCILANTES |         |  | OSCILANTES                 |         |  |
| CANT.      | COD.    |  | CANT.                      | COD.    |  |
| 4          | 0541-42 |  | 4                          | 0541-42 |  |
|            |         |  |                            |         |  |

| YOMEL - CL 1500 - ME 1500 - 3PLZ - HO 1500 - 3P1500 |         |  | YOMEL - 265-S |         |  |
|---|---------|--|---------------|---------|--|
| OSCILANTES  |         |  | OSCILANTES    |         |  |
| CANT.   | COD.    |  | CANT.         | COD.    |  |
| 2   | 0500-01 |  | 4             | 1540-21 |  |
|   |         |  |               |         |  |

| YOMEL - 1510 - 1810 - 1820 - 1821 |      |  |                         |      |  |                  |      |  |
|-----------------------------------|------|--|-------------------------|------|--|------------------|------|--|
| OSCILANTES                        |      |  | Conj. PERNO             |      |  | BUJE             |      |  |
| CANT.                             | COD. |  | CANT.                   | COD. |  | CANT.            | COD. |  |
| 2 (AH)                            | 1518 |  | Conj. Perno <b>0838</b> |      |  | Buje <b>0868</b> |      |  |
|                                   |      |  |                         |      |  |                  |      |  |

| YOMEL - Moscato OM 540 - 285 |         |  | YOMEL - Moscato 3.2 (Modelo Nuevo) |      |  |
|------------------------------|---------|--|------------------------------------|------|--|
| OSCILANTES                   |         |  | OSCILANTES                         |      |  |
| CANT.                        | COD.    |  | CANT.                              | COD. |  |
| 4                            | 0500-01 |  | 4                                  | 1129 |  |
|                              |         |  |                                    |      |  |

(AH) AntiHorario / (H) Horario: SENTIDO DE GIRO

# CUCHILLAS DESMALEZADORAS /

CATÁLOGO Nro 133 Marzo 2024

| YOMEL - Moscato 3.2 - 3210 - 3220 |      |            |      |                  |  |
|-----------------------------------|------|------------|------|------------------|--|
| OSCILANTES                        |      | OSCILANTES |      | Conj. PERNO      |  |
| CANT.                             | COD. | CANT.      | COD. | COD.             |  |
| 4                                 | 0509 | 4          | 0510 | Conj. Perno 0839 |  |
|                                   |      |            |      |                  |  |

| YOMEL - 3C 4310 |      |       |      |                  |  |           |  |
|-----------------|------|-------|------|------------------|--|-----------|--|
| OSCILANTES      |      | FIJAS |      | Conj. PERNO      |  | BUJE      |  |
| CANT.           | COD. | CANT. | COD. | COD.             |  | COD.      |  |
| 6               | 0881 | 4     | 0510 | Conj. Perno 0839 |  | Buje 0866 |  |
|                 |      |       |      |                  |  |           |  |

| YOMEL - TM2350 - TAC 6500 - 3 C 4300 |      |                  |  |           |  |
|--------------------------------------|------|------------------|--|-----------|--|
| OSCILANTES                           |      | Conj. PERNO      |  | BUJE      |  |
| CANT.                                | COD. | COD.             |  | COD.      |  |
| 4                                    | 1124 | Conj. Perno 0839 |  | Buje 0866 |  |
|                                      |      |                  |  |           |  |

| INSERTOS DE RECAMBIO |         |           |
|----------------------|---------|-----------|
| LARGO                | DERECHO | IZQUIERDO |
| COD.                 | COD.    | COD.      |
| 0921                 | 0940    | 0941      |
|                      |         |           |

(AH) AntiHorario / (H) Horario: SENTIDO DE GIRO

# MOVIMIENTO DE TIERRA /

CATÁLOGO Nro 133 Marzo 2024

## MAINERO - PALA MOD. 701

### ESQUEMA



### COMPOSICION

| CANT. | COD.        | DESCRIPCIÓN               |
|-------|-------------|---------------------------|
| 1     | <b>0467</b> | CUCHILLA CENTRAL          |
| 2     | <b>0464</b> | CUCH. DERECHA E IZQUIERDA |

## GROSSPAL - PALA MOD. COLONIAL 150

### ESQUEMA

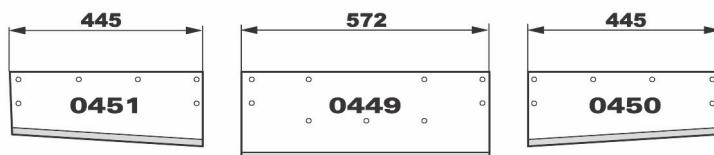

### COMPOSICION

| CANT. | COD.        | DESCRIPCIÓN             |
|-------|-------------|-------------------------|
| 1     | <b>0451</b> | CUCHILLA LAT. IZQUIERDA |
| 1     | <b>0449</b> | CUCHILLA CENTRAL        |
| 1     | <b>0450</b> | CUCHILLA LAT. DERECHA   |

## GROSSPAL - PALA MOD. NOVA 125

### ESQUEMA

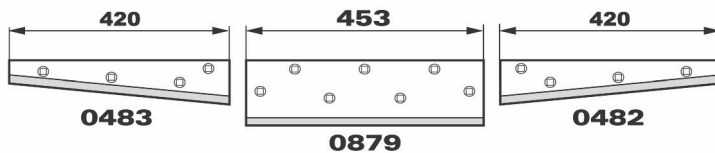

### COMPOSICION

| CANT. | COD.        | DESCRIPCIÓN             |
|-------|-------------|-------------------------|
| 1     | <b>0482</b> | CUCHILLA LAT. IZQUIERDA |
| 1     | <b>0879</b> | CUCHILLA CENTRAL        |
| 1     | <b>0483</b> | CUCHILLA LATD ERECHA    |

## GROSSPAL - PALA MOD. NOVA 150

### ESQUEMA

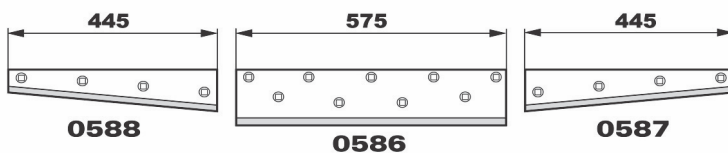

### COMPOSICION

| CANT. | COD.        | DESCRIPCIÓN             |
|-------|-------------|-------------------------|
| 1     | <b>0587</b> | CUCHILLA LAT. IZQUIERDA |
| 1     | <b>0586</b> | CUCHILLA CENTRAL        |
| 1     | <b>0588</b> | CUCHILLA LAT. DERECHA   |

## GROSSPAL - PALA MOD. NOVA 200

### ESQUEMA

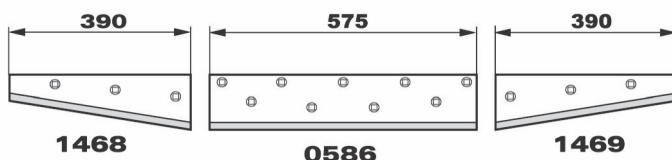

### COMPOSICION

| CANT. | COD.        | DESCRIPCIÓN             |
|-------|-------------|-------------------------|
| 1     | <b>1469</b> | CUCHILLA LAT. IZQUIERDA |
| 1     | <b>0586</b> | CUCHILLA CENTRAL        |
| 1     | <b>1468</b> | CUCHILLA LAT. DERECHA   |

## MANCINI - PALA 1,50 mts.

### ESQUEMA

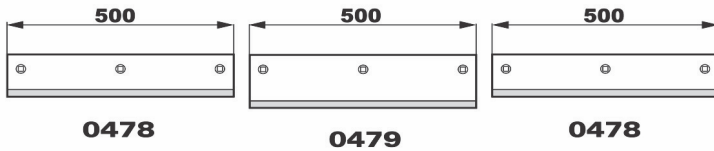

### COMPOSICION

| CANT. | COD.        | DESCRIPCIÓN               |
|-------|-------------|---------------------------|
| 1     | <b>0479</b> | CUCHILLA CENTRAL          |
| 2     | <b>0478</b> | CUCH. DERECHA E IZQUIERDA |

## MONTERREY - PALA 1,50 mts.

### ESQUEMA

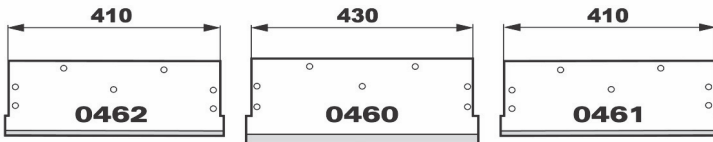

### COMPOSICION

| CANT. | COD.        | DESCRIPCIÓN             |
|-------|-------------|-------------------------|
| 1     | <b>0461</b> | CUCHILLA LAT. IZQUIERDA |
| 1     | <b>0460</b> | CUCHILLA CENTRAL        |
| 1     | <b>0462</b> | CUCHILLA LAT. DERECHA   |

## MONTERREY - PALA 2,50 mts.

### ESQUEMA

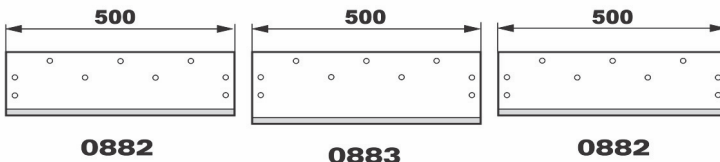

### COMPOSICION

| CANT. | COD.        | DESCRIPCIÓN               |
|-------|-------------|---------------------------|
| 1     | <b>0883</b> | CUCHILLA CENTRA           |
| 2     | <b>0882</b> | CUCH. DERECHA E IZQUIERDA |

## PALAS PARA MOTONIVELADORAS

### ESQUEMA

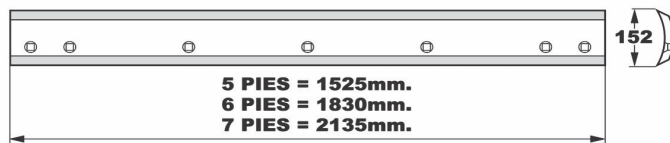

### COMPOSICION

| COD.        | DESCRIPCIÓN              |
|-------------|--------------------------|
| <b>0659</b> | CUCHILLA 5 PIES (1525mm) |
| <b>0456</b> | CUCHILLA 6 PIES (1830mm) |
| <b>0658</b> | CUCHILLA 7 PIES (2135mm) |
| <b>1472</b> | BULON C/TUERCA           |



# CUCHILLAS PICADORAS /

CATÁLOGO Nro 133 Marzo 2024

| AGROMECA (MIXER)  |  |                   |  |               |  |
|-------------------|--|-------------------|--|---------------|--|
| MARTILLO MOLEDORA |  | DESMEN. DE ROLLOS |  | MARTILLO FIJO |  |
| CODIGO            |  | CODIGO            |  | CODIGO        |  |
| 0444              |  | 0452              |  | 1148          |  |
|                   |  |                   |  |               |  |



| MAINERO PICADORA ROTOR UF 150 y UF150X |  |                   |  |                   |      |
|--|--|-------------------|--|-------------------|------|
| CUCHILLA PICADORA                      |  | CUCHILLA PICADORA |  | BUJE / ESP ARRAGO |      |
| CODIGO                                 |  | CODIGO            |  | DESCR.            | COD. |
| 0580                                   |  | 0980              |  | Buje              | 0435 |
|  |  |                   |  | Esparrago         | 0437 |
|  |  |                   |  |                   |      |



| MARANI AUTOMOTRIZ (APLICABLE A MAINERO) |  |
|---|--|
| CUCHILLA CORTADORA DEL PLATO            |  |
| CODIGOS                                 |  |
| 2230 / 2231                             |  |
| 1182 / 1183 (mod. viejo)                |  |
|   |  |

| TEMPLAR PICADORA DE RASTROJO |  |                |  |
|------------------------------|--|----------------|--|
| PICADORA CURVA               |  | PICADORA CURVA |  |
| CODIGO                       |  | CODIGO         |  |
| 0408                         |  | 1125           |  |
|                              |  |                |  |

| TRITURADORAS PARA ROLOS |            |
|-------------------------|------------|
| PICADOR DE RASTROJO     |            |
| CODIGO                  | PRECIO c/u |
| 1773                    |            |
|                         |            |

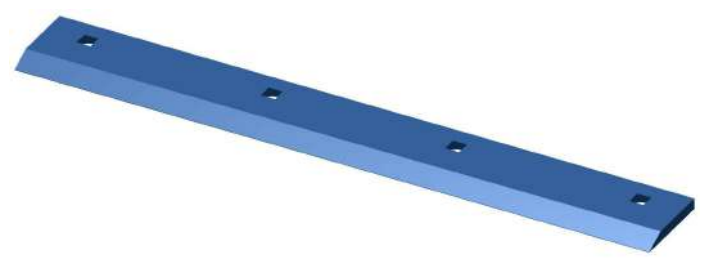

## ALETAS DE ROLOS MAICEROS

| CODIGO | DESCRIPCION                           |
|--------|---------------------------------------|
| 0988   | ALETA PARA ROLO MAINERO               |
| 1130   | ALETA PARA ROLO TECNORURAL / VASSALLI |

## CUCHILLAS DE TRITURADOR

### SALVATELLI

### JOHN DEERE

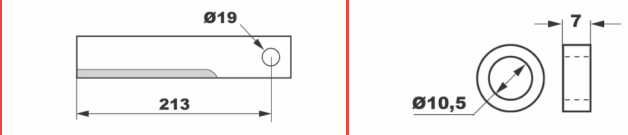
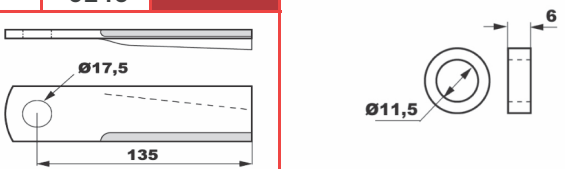
| CUCHILLAS |      |  | BUJE  |      |  | CUCHILLAS  |      |  | BUJE   |      |  |
|-----------|------|--|-------|------|--|--|------|--|--|------|--|
| DESCR.    | COD. |  | CANT. | COD. |  | DESCR.   | COD. |  | CANT.  | COD. |  |
| IZQ.      | 0245 |  | 2     | 0151 |  | REVERS   | 1683 |  | 1  | 0991 |  |
| DER.      | 0246 |  |       |      |  |  |      |  |  |      |  |
|           |      |  |       |      |  | FILO + MARTILLO REVERSIBLE   |      |  |  |      |  |

### MASSEY FERGUSON - DEUTZ

### NEW HOLLAND

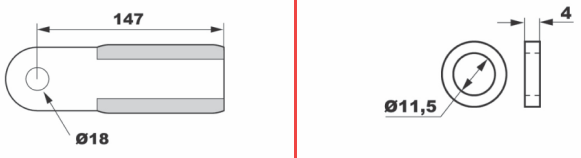
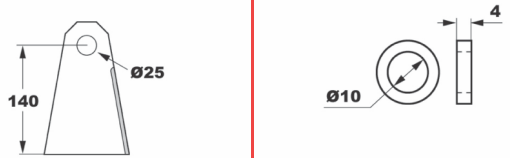
| CUCHILLAS   |      |  | BUJE  |      |  | CUCHILLAS  |      |  | BUJE  |      |  |
|---|------|--|-------|------|--|--|------|--|-------|------|--|
| DESCR.  | COD. |  | CANT. | COD. |  | DESCR.   | COD. |  | CANT. | COD. |  |
| D. FILO   | 0243 |  | 1     | 0336 |  | D. FILO  | 0375 |  | 1     | 0914 |  |
|  |      |  |       |      |  |  |      |  |       |      |  |

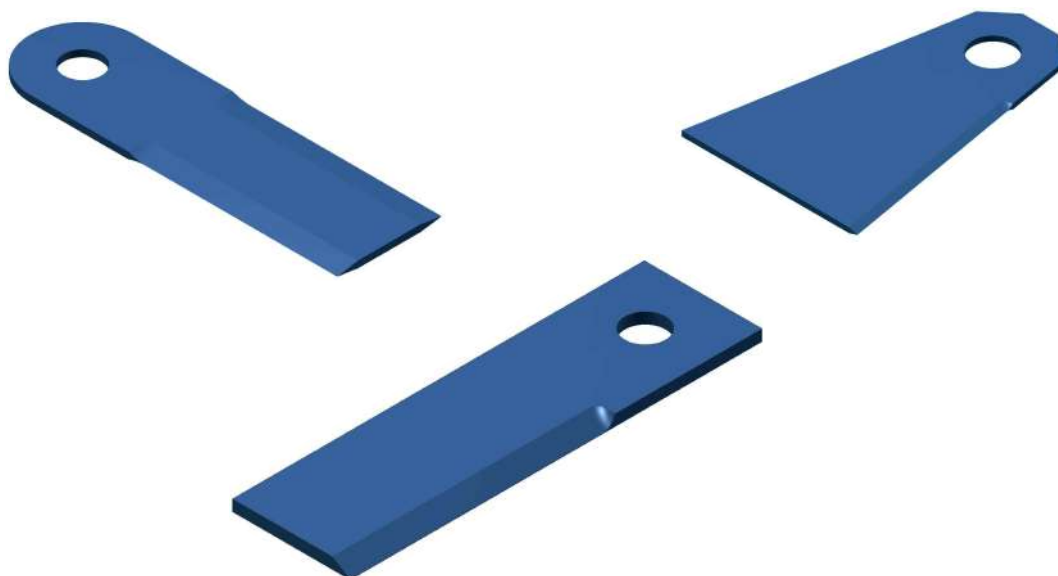



**Agroflex<sup>®</sup>**

☎ Tel +54 9 341 576-8333 / +54 9 341 610-2987 / +54 341 457-0400

🌐 [www.agroflex.com.ar](http://www.agroflex.com.ar)

✉ [agroflex@metaltecnica.com.ar](mailto:agroflex@metaltecnica.com.ar)

📷 @agroflex.oficial